

Installation Manual

eSENSE Duct (Disp)



Figure 1 The eSENSE Duct with and without display

General

The IAQ-sensor product eSENSE Duct (for mounting in ventilation ducts) is designed to measure carbon dioxide (CO₂). Option - TR is prepared for temperature measurements by the resistive temperature probe mounted by the user. Option -Disp displays the measured CO₂ value in ppm (parts-per-million) on the LCD.

The units are designed for connecting to Direct Digital Control (DDC) with 0-10V or 2-10V signal inputs. The two parallel signal outputs Out(1) (0-10V) and Out(2) (2-10V or 4-20 mA) give linear signal voltages or currents corresponding to the measuring range.

The output Out(2) also indicates the *status* by setting the output voltage to 1V or the output current to 2 mA when the sensor self-diagnostics detects any error.

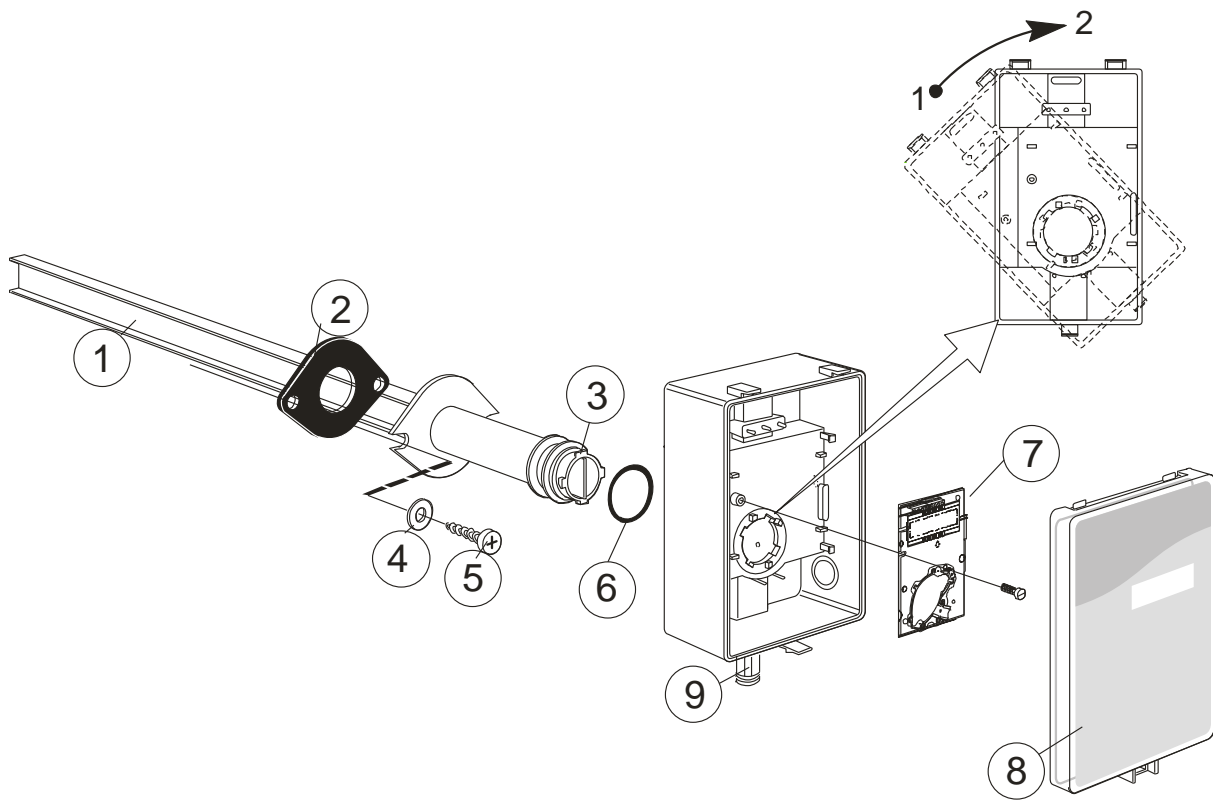

1 Sampling probe
2 Sealing gasket

3 Largest locking nob
4 2 washers (Not included)
5 2 screws (Not included)

6 O-ring 29,2x3,53
7 PCB
(Factory supplied mounted in box)
8 Snap-in lid
9 Cable entry bushing

Figure 2 Parts of the eSENSE for duct mounting

Mounting of eSENSE on to the duct.

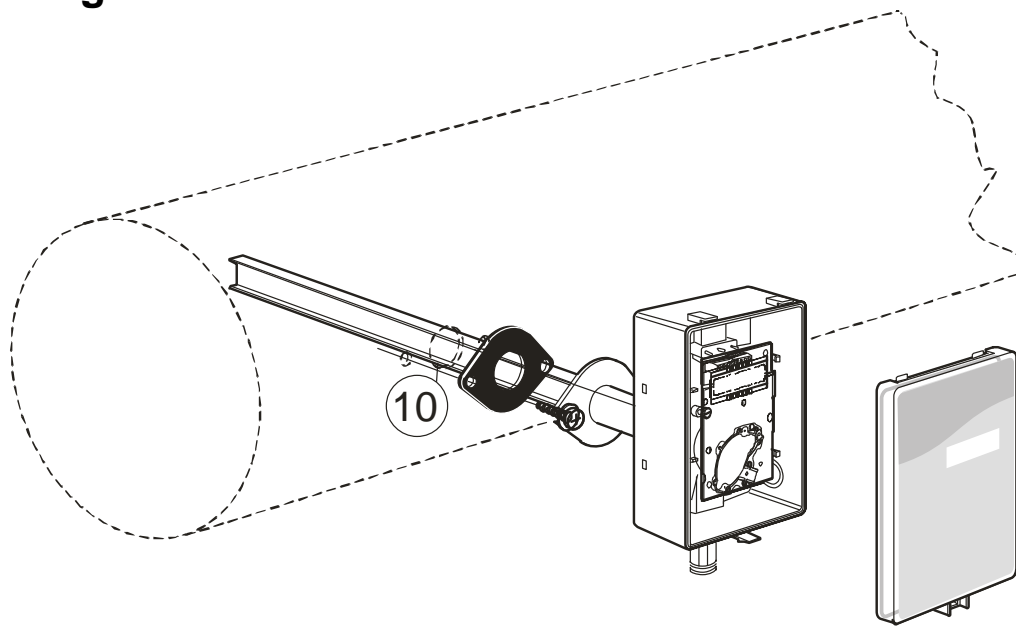

10 Hole with 25 mm diameter

Figure 3 Mounting of the sensor to the ventilation duct

Mounting Instruction

Since there might be a substantial pressure difference in duct mounting applications, it is essential to avoid ambient air from suction into the duct mounting box. For correct function it is indispensable that the sealing of the box cover, the cable entry bushings, the cable feed through and the duct entrance are absolutely tight. The duct entrance may need extra sealing paste in order to prevent leakage. The PCB must be handled carefully and protected from electrostatic discharge.

- 1) **Place the O-ring** around the hole at the back of the box. See figure 2.
- 2) **Electrical cable entry:** The box has a factory mounted cable entry bushing. Never feed more than one cable through each cable entry bushing, or else gas might leak through!
- 3) **Mounting the tube:** Drill a hole (10) with 25 mm diameter (or 1 inch) for the sampling probe and two holes with 4 mm diameter for the screws (5) into the air duct and mount the tube (1) with the gasket (2). The sampling probe should be mounted with the largest locking knob on top. The unit can be mounted with the air coming from the left or right.
- 4) **Attaching the sensor box** is made to the sampling probe by a snap-in bayonet fitting. Orient the box onto the sampling probe so that the box upside is on the same side as the largest locking knob (3). When the probe is fitted into the notches of the box, then turn the box clockwise until stop (see Figure 2). Position 1 indicates *open* where the box can be removed from the sampling probe. In position 2 the box is locked to the probe.

Electrical connections

The power supply has to be connected to \sim \oplus and \ominus . \ominus is considered as system ground. The same ground reference has to be used for the eSENSE unit and for the DDC/signal receiver.



PLEASE NOTE!

The same ground reference has to be used for the eSENSE unit and for the control system!

Terminal	Function	Electrical data	Remarks Standard settings	Remarks Settings of this sensor
\sim \oplus	Power (+)	24 VAC/DC+ (+-20%), 2W		
\ominus	Power ground (-)	24 VAC/DC-	System voltage reference	
Out(1)	Analogue output 1 (+)	0-10 VDC or According to label	0-2000 ppm CO ₂	
Out(2)	Analogue output 2 (+)	2,0...10,0 VDC or 4,0 ... 20,0 mA or According to label	0-2000 ppm CO ₂	
		0,9...1,6 VDC or 1.5 to 2,5 mA	Status = ERROR	
		0 VDC or 0mA	Status = NOT READY	

Table I. Connections of the main terminal of eSENSE

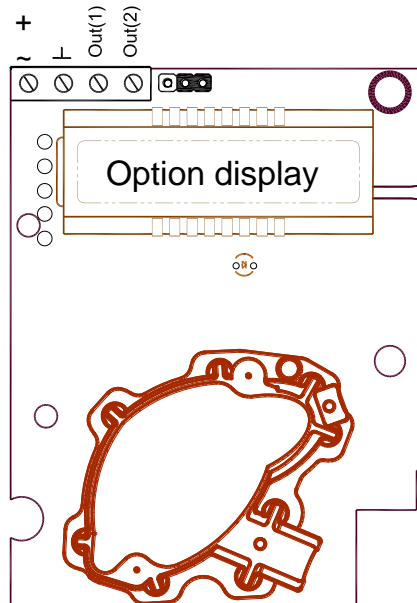

Figure 4 PCB with jumper to configure OUT2 for current output 4-20mA or voltage output 2-10VDC

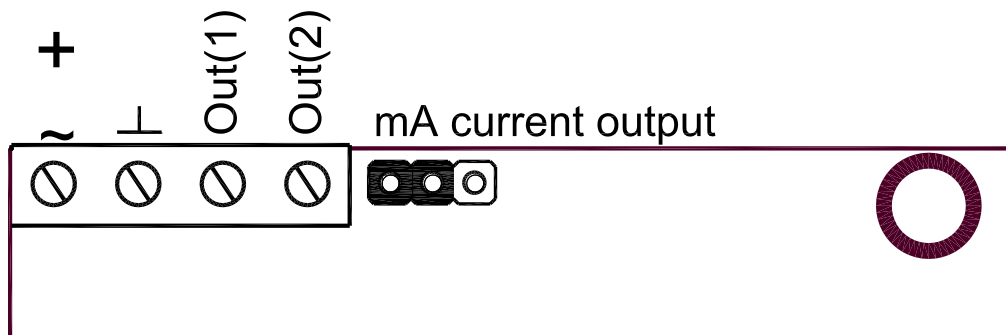

Figure 5 Enlarged picture of the PCB with the jumper set to current output (left position)

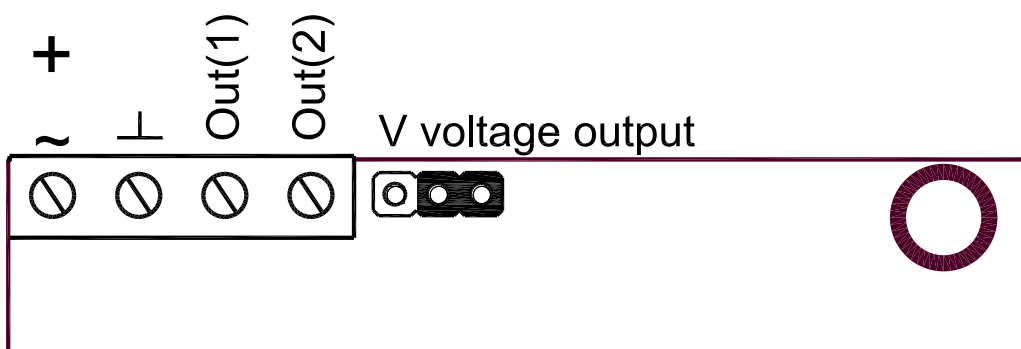

Figure 6 Enlarged picture of the PCB with the jumper set to voltage output (right position)

Self-diagnostics

The system contains a complete self-diagnostic procedure that is executed automatically when the sensor is in operation. Sensors with display show a *wrench* if an error is found. The wrench is shown during the first seconds after power up and if the measuring range is exceeded. The output Out(2) indicates the same information by setting the output voltage to 1V or 2 mA.

Maintenance

The *eSENSE* is basically maintenance free in normal environments thanks to the built-in self-correcting *ABC* algorithm. Discuss your application with SenseAir in order to get advice for a proper calibration strategy.

PLEASE NOTE!

The sensor accuracy is defined at continuous operation (at least 3 weeks after installation)

PLEASE NOTE! Electronic products should be disposed of via a suitable recycling centre.

Dimensions

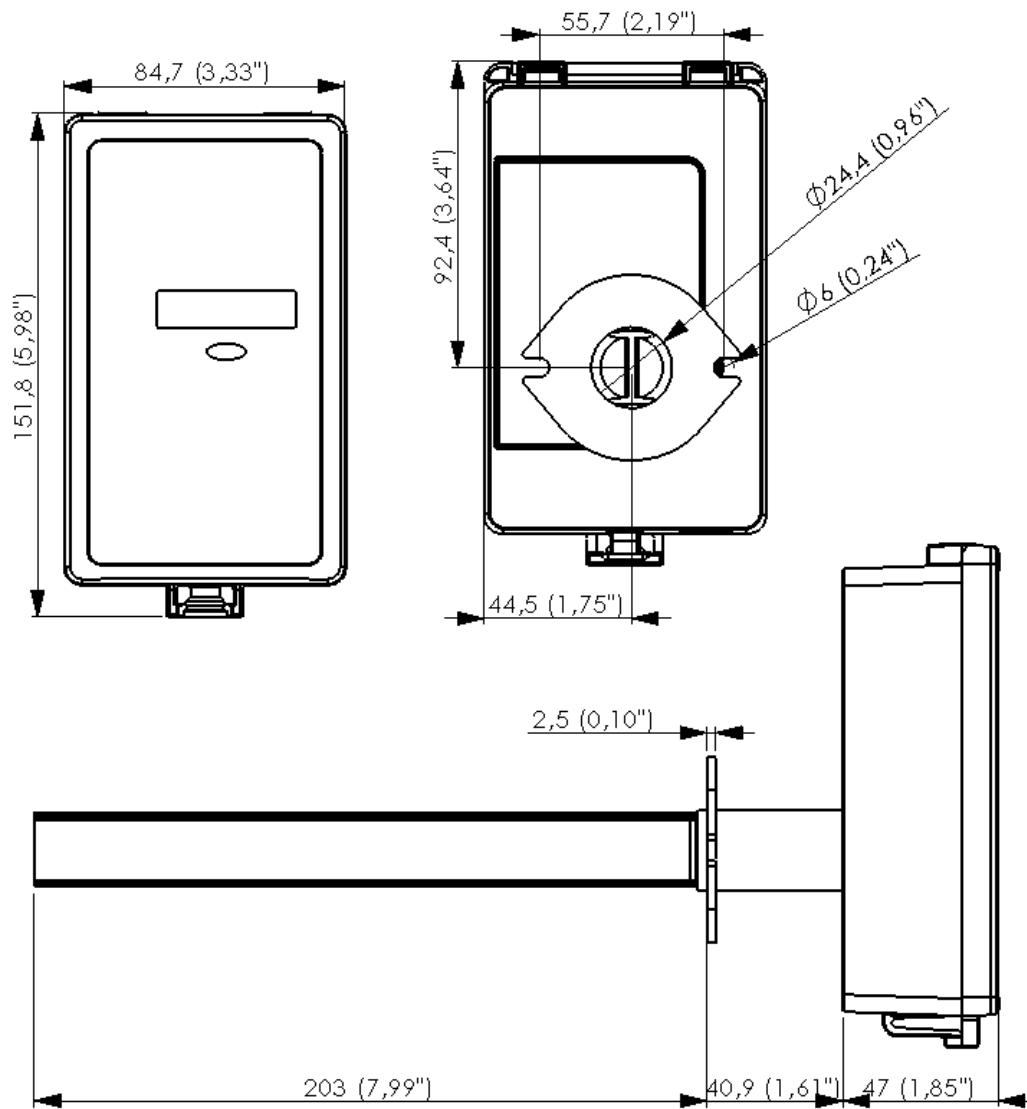

Figure 7 The dimensions of the sensor in mm and (inches)

This product is in accordance with the EMC 2004/108/EC, 92/31/EEG including amendments by the CE-marking Directive 93/68/EEC

The product fulfils the following demands: EN 61000-4-2 level 2, EN 61000-4-3 level 2, EN 61000-4-4 level 4, EN 61000-4-6, EN 61000-4-8 level 4, EN 55022 class B



SenseAir[®] AB (headquarter)

Stationsgatan 12
Box 96
820 60 Delsbo
SWEDEN

Phone: +46-(0)653 - 71 77 70

E-mail: info@senseair.com

Web site: www.senseair.com