

Product Specification

Senseair S8-4BP

Miniature CO₂ sensor safety switch

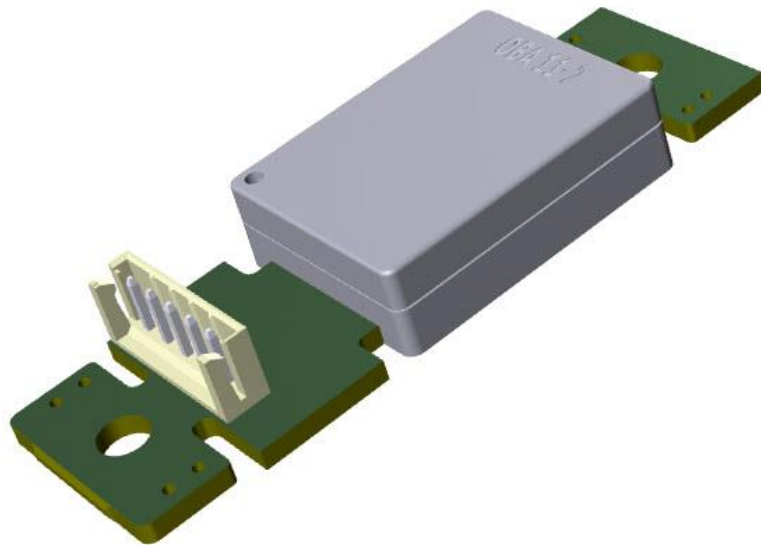

General

Senseair S8-4BP CO₂ sensor module is designed to serve as a CO₂ safety switch when built-in into kerosene heaters. The sensor utilises reliable and highly accurate infrared gas sensing technology. The electronic circuitry is optimised for low power consumption.

Table of Contents

General	1
Sample gas diffusion area	4
Pin configuration and functions	5
Pin configuration	5
Pin functions	5
Maintenance and test jumpers.....	6
Specifications.....	7
Absolute maximum ratings.....	7
Recommended operating conditions	7
Outputs functionality and parameters.....	8
Outputs operation.....	8
Measurement mode	9
Dimensions	9
Maintenance and test.....	9
Calibration restore switch S1	9
Test mode switch S2	10
Compliance.....	11
Package.....	12

Item	Senseair S8-4BP Article No. 004-0-0083
Target gas	Carbon dioxide (CO ₂)
Operating principle	Non-dispersive infrared (NDIR)
Operating range	-20–55 °C, 0–90% RH (non-condensing), (see figure 3)
Measurement range	400–15000 ppm (represented internally in digital format) ¹
Accuracy [CO ₂]	±1000 ppm at alarm points between 7000ppm and 9000ppm ^{2, 3}
Output alarm threshold [CO ₂]	7500ppm ⁴
Ventilate warning threshold [CO ₂]	6500ppm ⁴
Battery low warning threshold	5.3V ±5% ⁴
Sampling interval	105 sec ±5% for < 6500ppm 30 sec ±5% for > 6500ppm
Pressure dependence	1.6% reading per kPa deviation from normal pressure
Hysteresis of Alarm and Ventilation warning thresholds [CO ₂]	1000ppm
Power supply	4.3–7.0V ⁵
Peak current	100 mA ±10%
Average current	< 2mA ⁶
Maintenance and test	Forced calibration test pads. Forced alarm test pads. Self-diagnostics ^{6, 7}
Dimensions (L x W x H)	59.9x19.7x9.6mm
Storage temperature	-40–70 °C
Weight	< 10g

Table 1 General specifications

- Note 1: Sensor is designed to measure with best accuracy in the range 7000–9000ppm, which is specified in the table accuracy. Nevertheless, exposure to concentrations below 400ppm may result in incorrect operation of ABC algorithm and shall be avoided.
- Note 2: Accuracy is specified over operating range 5–30 °C, 0–80% RH.
- Note 3: Specification is referenced to uncertainty of calibration gas mixtures (±1%).
- Note 4: For description of outputs functionality and parameters refer chapter Outputs functionality and parameters.
- Note 5: Unprotected against surges and reverse power supply polarity.
- Note 6: Average current varies below and above measured 6500ppm level due to difference in sampling interval.
- Note 7: For maintenance and test description refer chapter Maintenance and test.

Sample gas diffusion area

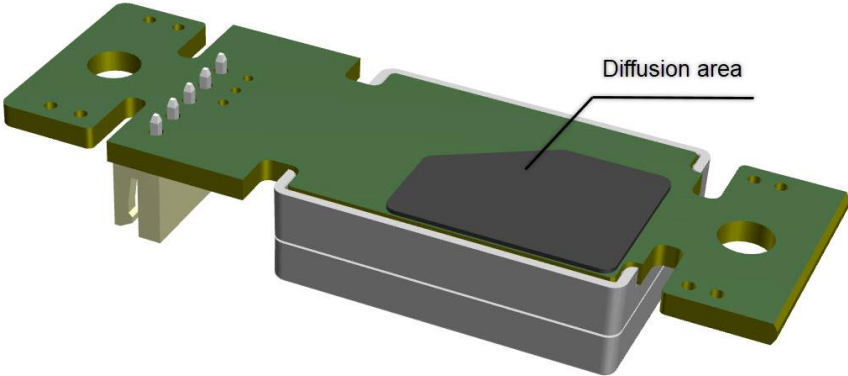

Figure 1 Sample gas diffusion area

Note 1: Diffusion area must not be covered. Diminished sample gas circulation may affect response time.

Pin configuration and functions

Pin configuration

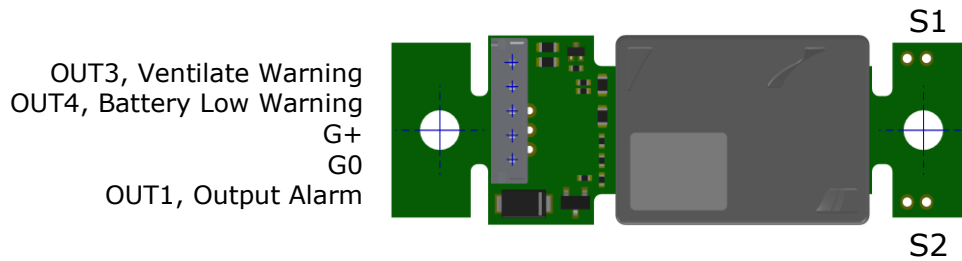

Figure 2 Pin configuration (top view)

Pin functions

Pin #	Symbol	I/O Type	Description
1	OUT1, Output alarm	Output	Open drain output for alarm indication. Internally protected to operate on inductive load. Maximum current 100mA, Internally pulled up by 100k to G+
2	G0	Power	Power supply negative terminal. Sensor's reference (ground) terminal.
3	G+	Power	Power supply positive terminal. Unprotected against surges and reverse power supply polarity.
4	OUT4, Battery low warning	Output	Pulled up to G+ at processor reset (power up and power down) Built in series 390R resistor for direct LED driving
5	OUT3, Ventilate warning	Output	Pulled up to G+ at processor reset (power up and power down) Built in series 390R resistor for direct LED driving

Table 2 Pin functions

Maintenance and test jumpers

#	Symbol	I/O Type	Description
1	S1 Calibration restore switch	Input	<p>Digital input forcing background calibration. Background calibration is activated when closed for minimum 105 sec assuming 400ppm CO₂ sensor exposure. Calibration occurs every 105 sec during switch grounding ¹.</p> <p>Absolute max voltage range ² -0.3–3.8V Internal pull up resistor 120k Ohm Input low level ² -0.3–0.75V Input high level ² 2.3–3.6V</p> <p>No internal protection, Internal pull-up to 3.3V at processor reset (power up and power down).</p>
2	S2 Forced output test	Input	<p>Digital input enabling outputs test mode (when closed for minimum 105 sec).</p> <p>Absolute max voltage range ² -0.3–3.8V Internal pull up resistor 120k Ohm Input low level ² -0.3–0.75V Input high level ² 2.3–3.6V</p> <p>No internal protection, Internal pull-up to 3.3V at processor reset (power up and power down).</p>

Table 3 Jumpers functions

Note 1: Do not ground bCal input for long time. FLASH resource will be exhausted in 3.5 months in case of permanent bCal grounding.

Note 2: Specified parameter relies on specification of subcontractor and is not tested by Senseair.

Specifications

Absolute maximum ratings

Over operating temperature range (unless otherwise noted); all voltages are with respect to G0 ¹

Symbol	Description	Min	Max	Unit
G+	Voltage on G+ pin with respect to G0 pin	-0.3	12	V
S1, S2 ²	Maximum voltage on Calibration restore (S1), Forced output test (S2) inputs	-0.3	3.8	V
OUT1 OUT3 OUT4 ³	Maximum voltage on: Output alarm Ventilate warning Battery low warning	-0.3	G+...+ 0.5	V

Table 4 Absolute maximum ratings

Note 1: Stresses beyond those listed under Absolute maximum ratings may cause permanent damage to the device. These are stress ratings only, which do not imply functional operation of the device at these or any other conditions beyond those indicated under Recommended operating conditions. Exposure to absolute-maximum-rated conditions for extended periods may affect device reliability.

Note 2: Specified parameter relies on specification of subcontractor and is not tested by Senseair.

Note 3: OUT1 (Output alarm), OUT3 and OUT4 pin are internally pulled up to G+. External pull up to higher voltage will provide resistive divider powering sensor via high resistance.

Recommended operating conditions

Over operating temperature range (unless otherwise noted)

Symbol	Description	Min	Typ	Max	Unit	Test conditions
Voltage						
G+	Supply voltage	4.3	5	7	V	

Table 5 Recommended operating conditions

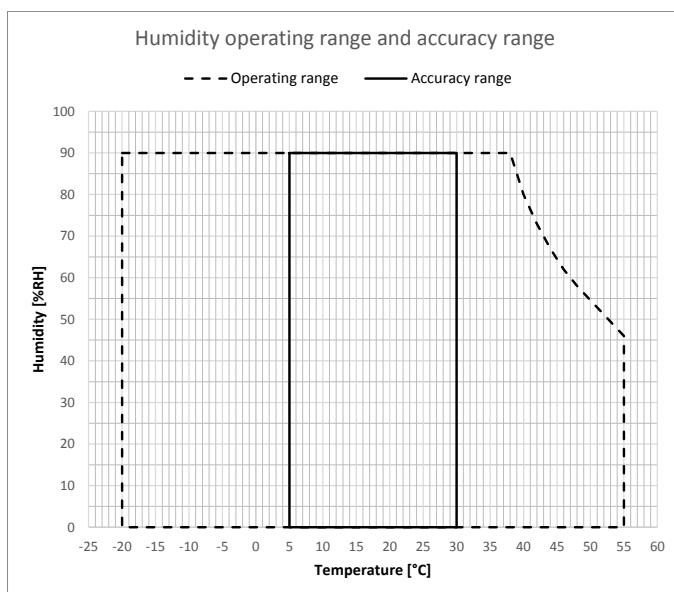

Figure 3 Operating range and accuracy range

Outputs functionality and parameters

Output	Name	Alarm conditions	Normal state
OUT1	Output alarm	3 consecutive CO ₂ samples above Output alarm threshold [CO ₂] OR 3 consecutive battery voltage samples below 4.3V unloaded or 4V loaded (lamp on) OR 3 consecutive samples of self-diagnostic error	Normally low / conducting to ground
OUT3	Ventilate warning	One CO ₂ samples above Ventilate Warning threshold [CO ₂]	Normally high / not conducting to ground
OUT4	Battery low warning	One battery voltage sample below Battery low warning threshold	Normally high / not conducting to ground

Table 6 Outputs functionality and parameters

Outputs operation

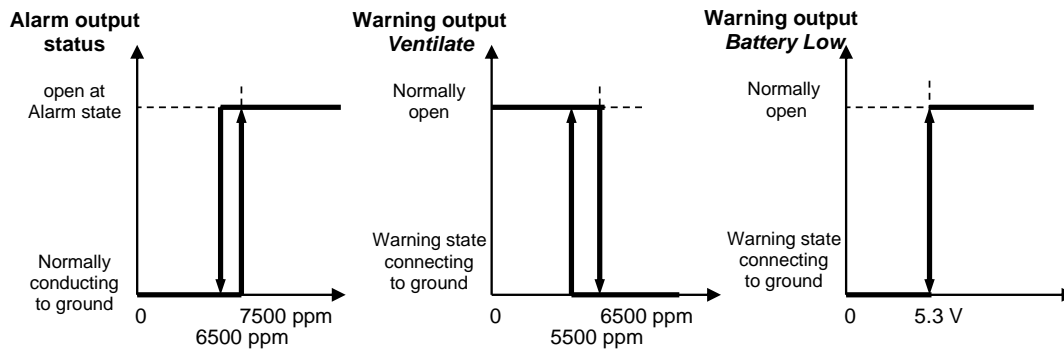

Figure 4 Outputs operation for S8-4BP

Measurement mode

The Senseair S8-4BP normally samples ambient CO₂ concentration once every 105 sec. As soon as measured concentration exceeds 6500ppm, measurement period decreases to 30 sec to provides faster reaction yet consistent with gas diffusion time.

Dimensions

Refer to drawing 740-01302.

Maintenance and test

Calibration restore switch S1

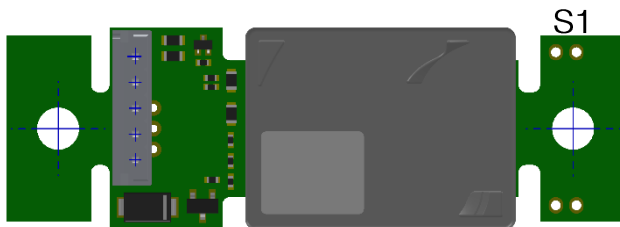

Figure 5 Calibration restore switch S1

If for some reason the sensor needs to be re-calibrated, this is possible to do by a qualified operator, provided that the sensor is exposed to fresh air during the whole process (~400ppm CO₂).

The process is actuated by creating an electrical short-cut between the two holes labeled S1. As soon as the micro-controller detects this manually shorted switch terminal S1, calibration is restored to fresh air concentration value.

The delay between the shorting of the switch contact S1 and the actual calibration may be up to 105 seconds.

If the operator keeps the sensor with S1 closed for some period of time, the sensor will continue to recalibrate fresh air concentration target value every 105 sec, until the switch is released.

Test mode switch S2

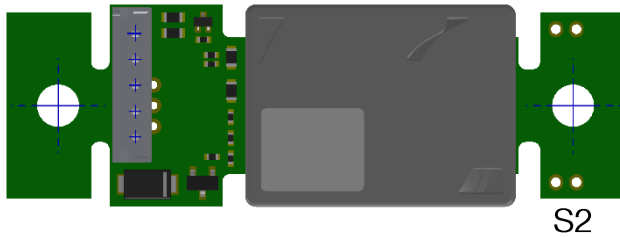

Figure 6 Test mode switch S2

This function is intended for a qualified operator to check the sensor outputs, and the subsequent system response, by a simulated sensor alarm and warnings condition.

The process is actuated by creating an electrical short-cut between the two holes labelled S2. A closure here will ground one of the micro-controller I/O pins. As soon as the micro-controller detects this manually grounded switch terminal, the Alarm output and Battery low warning outputs are actuated. The sensor, however, is in sleep mode most of the time, implying that the delay may be up to 105 seconds between the operator closure of the switch contact S2 and the time when the sensor actually responds to the forced output request. Moreover, the Ventilation output warning is actuated upon the release of the S2 closure. Therefore, as the operator executes the outputs test by realising the S2 short-cut, two outputs are responding first, and the Ventilation warning alarm comes second. In an installed sensor this might be hard to see, since normally the Kerosene heater will power down the sensor as soon as the operator induced S2 short-cut is detected.

If the operator leaves the sensor with S2 closed for some period of time, and if sensor power is yet available, the sensor will hold the outputs until the switch closure eventually is released and the Ventilation warning alarm is set until the next measurement cycle after about 30 seconds.

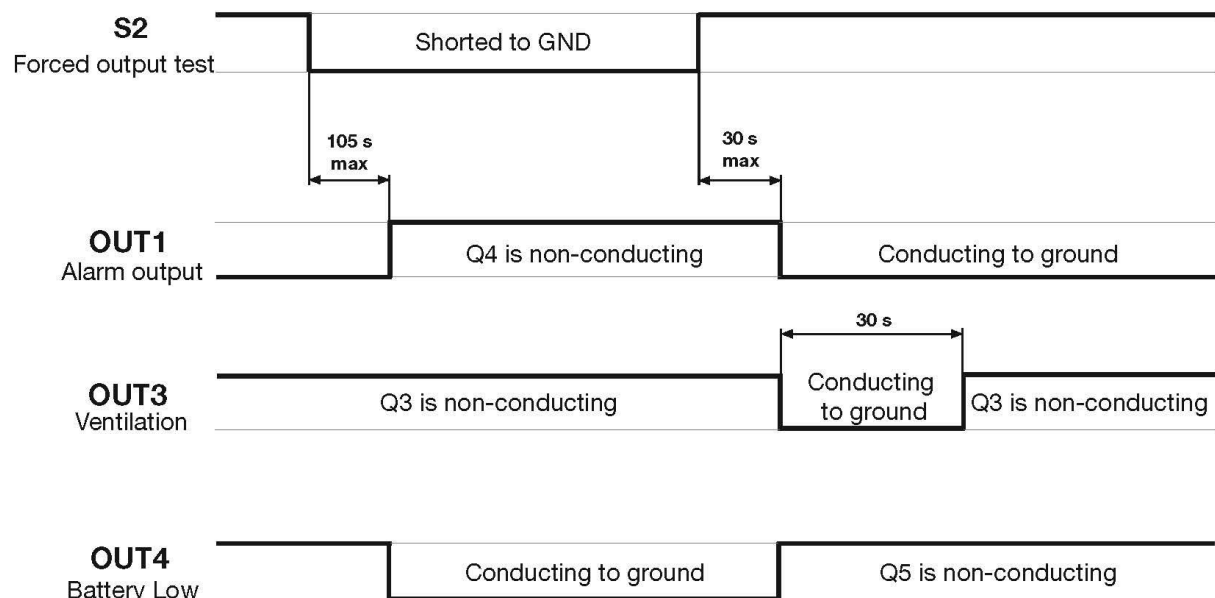

Figure 7 Outputs test mode

Compliance

EMC Directive 2014/30/EC

The equipment has been tested according to relevant parts of the “Electrical equipment for measurement, control and laboratory use” standard EN IEC 61326-1:2021, and has been found to comply with the required performance criteria stated therein.

Group 1 Class B emission requirements according to EN IEC 61326-1:2021

Industrial immunity requirements according to EN IEC 61326-1:2021

Additional information:

The equipment was tested mounted on an evaluation board. Additional testing might be needed mounted in the final application.

RoHS Directive 2015/863/EU

As manufacturer we declare, under our sole responsibility, that the equipment follows the provisions of the Directive stated above. It does not contain the following hazardous substances above the thresholds indicated in the directive, except in applications exempted from the restrictions, exemption 7(c)-I, lead in glass or ceramics:

- | | |
|---------------------------------|--|
| -Lead (Pb) | -Polybrominated Diphenyl Ethers (PBDE) |
| -Mercury (Hg) | -Bis(2-Ethylhexyl) phthalate (DEHP) |
| -Cadmium (Cd) | -Benzyl butyl phthalate (BBP) |
| -Hexavalent Chromium (CrVI) | -Dibutyl phthalate (DBP) |
| -Polybrominated Biphenyls (PBB) | -Diisobutyl phthalate (DIBP) |

EU REACH Regulation 1907/2006

The product does not contain any substances currently on the SVHC Candidate List in excess of 0,1% by weight per article. For the latest updated information contact Senseair.

WEEE Directive 2012/19/EU

Compliant

LNE NF 128

Compliant

Package

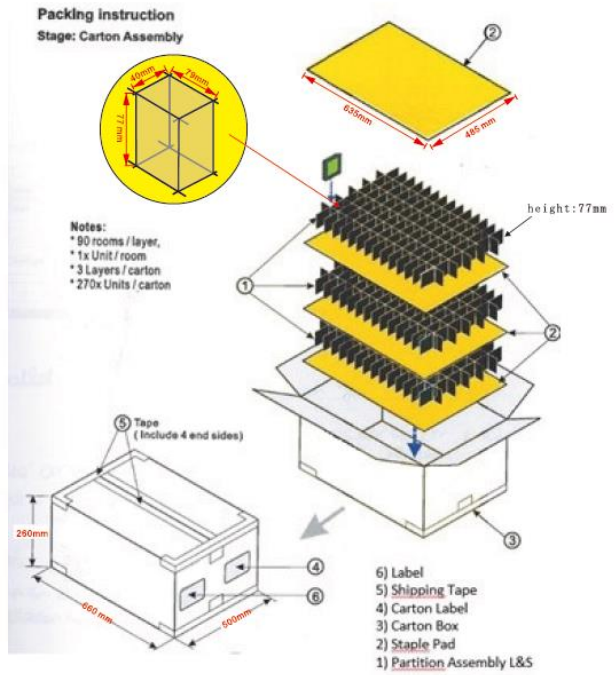
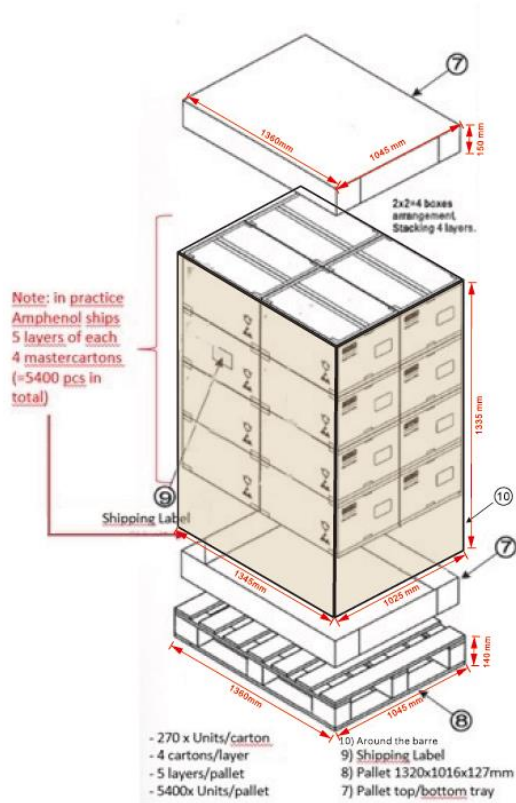

IMPORTANT NOTICE

1. Senseair reserves the right to make changes to the information contained in this document without notice. When you consider any use or application of Senseair product stipulated in this document ("Product"), please make inquiries the sales office of Senseair or authorised distributors as to current status of the Products.
2. All information included in this document are provided only to illustrate the operation and application examples of Senseair Products. Senseair neither makes warranties or representations with respect to the accuracy or completeness of the information contained in this document nor grants any license to any intellectual property rights or any other rights of Senseair or any third party with respect to the information in this document. You are fully responsible for use of such information contained in this document in your product design or applications. Senseair ASSUMES NO LIABILITY FOR ANY LOSSES INCURRED BY YOU OR THIRD PARTIES ARISING FROM THE USE OF SUCH INFORMATION IN YOUR PRODUCT DESIGN OR APPLICATIONS.
3. The Product is neither intended nor warranted for use in equipment or systems that require extraordinarily high levels of quality and/or reliability and/or a malfunction or failure of which may cause loss of human life, bodily injury, serious property damage or serious public impact, including but not limited to, equipment used in nuclear facilities, equipment used in the aerospace industry, medical equipment, equipment used for automobiles, trains, ships and other transportation, traffic signaling equipment, equipment used to control combustions or explosions, safety devices, elevators and escalators, devices related to electric power, and equipment used in finance-related fields. Do not use Product for the above use unless specifically agreed by Senseair in writing.
4. Though Senseair works continually to improve the Product's quality and reliability, you are responsible for complying with safety standards and for providing adequate designs and safeguards for your hardware, software and systems which minimise risk and avoid situations in which a malfunction or failure of the Product could cause loss of human life, bodily injury or damage to property, including data loss or corruption.
5. Do not use or otherwise make available the Product or related technology or any information contained in this document for any military purposes, including without limitation, for the design, development, use, stockpiling or manufacturing of nuclear, chemical, or biological weapons or missile technology products (mass destruction weapons). When exporting the Products or related technology or any information contained in this document, you should comply with the applicable export control laws and regulations and follow the procedures required by such laws and regulations. The Products and related technology may not be used for or incorporated into any products or systems whose manufacture, use, or sale is prohibited under any applicable domestic or foreign laws or regulations.
6. Please contact Senseair sales representative for details as to environmental matters such as the RoHS compatibility of the Product. Please use the Product in compliance with all applicable laws and regulations that regulate the inclusion or use of controlled substances, including without limitation, the EU RoHS Directive. Senseair assumes no liability for damages or losses occurring as a result of noncompliance with applicable laws and regulations.
7. Resale of the Product with provisions different from the statement and/or technical features set forth in this document shall immediately void any warranty granted by Senseair for the Product and shall not create or extend in any manner whatsoever, any liability of Senseair.
8. This document may not be reproduced or duplicated, in any form, in whole or in part, without prior written consent of Senseair.

www.senseair.com